

创新科技 丰富人类生活

&lg_ã2100/d

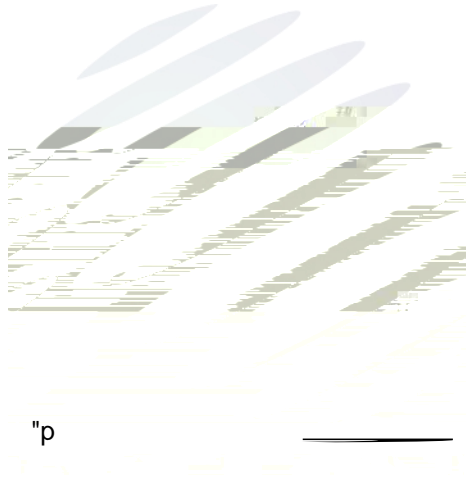

"p

1.

1.1 General Description

1.2

1.3

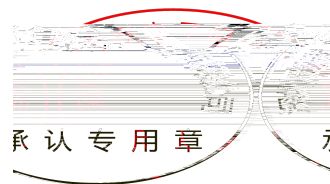



1.5

			B0	1.8	--	2.0	V
			C0	2.0	--	2.2	V
			D0	2.2	--	2.4	V
			E0	2.4	--	2.6	V
			F0	2.6	--	2.8	V
			G0	2.8	--	3.0	V
			2K	585	--	590	nm
			2L	590	--	595	nm
			K00	530	--	800	mcd
			L00	800	--	1200	mcd
			M00	1200	--	1800	mcd
			N00	1800	--	2800	mcd
							μ

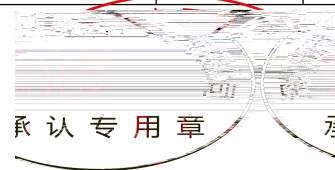

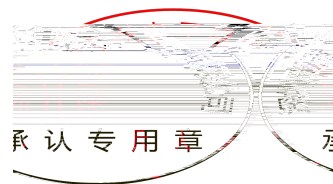
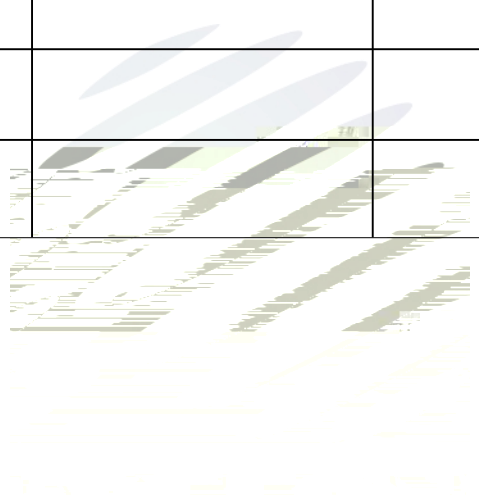

1.

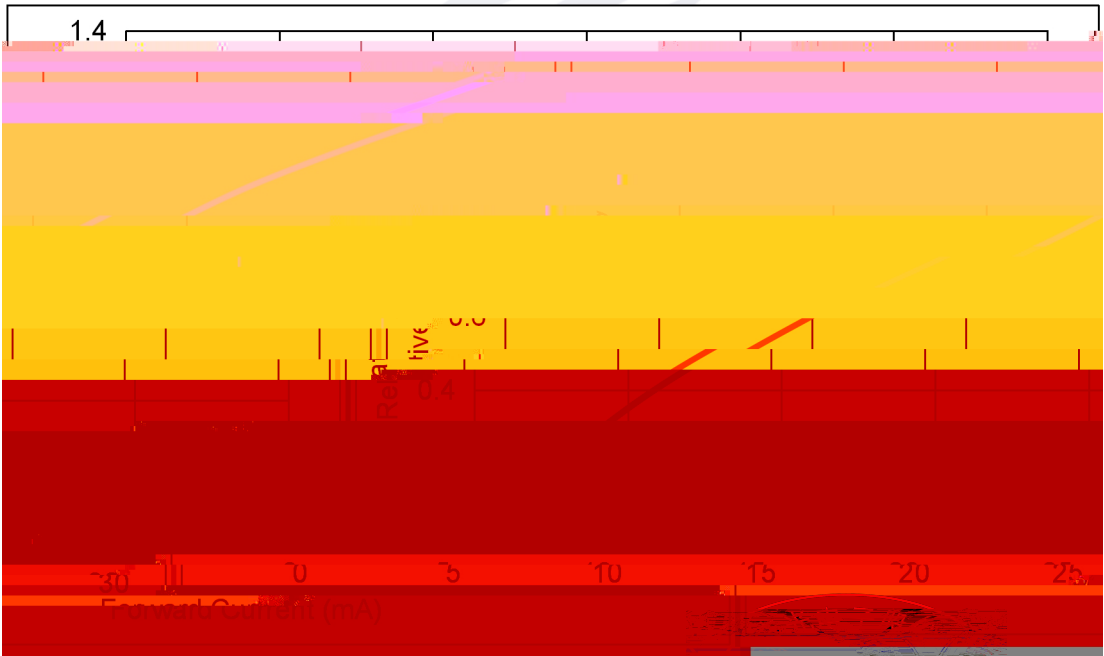
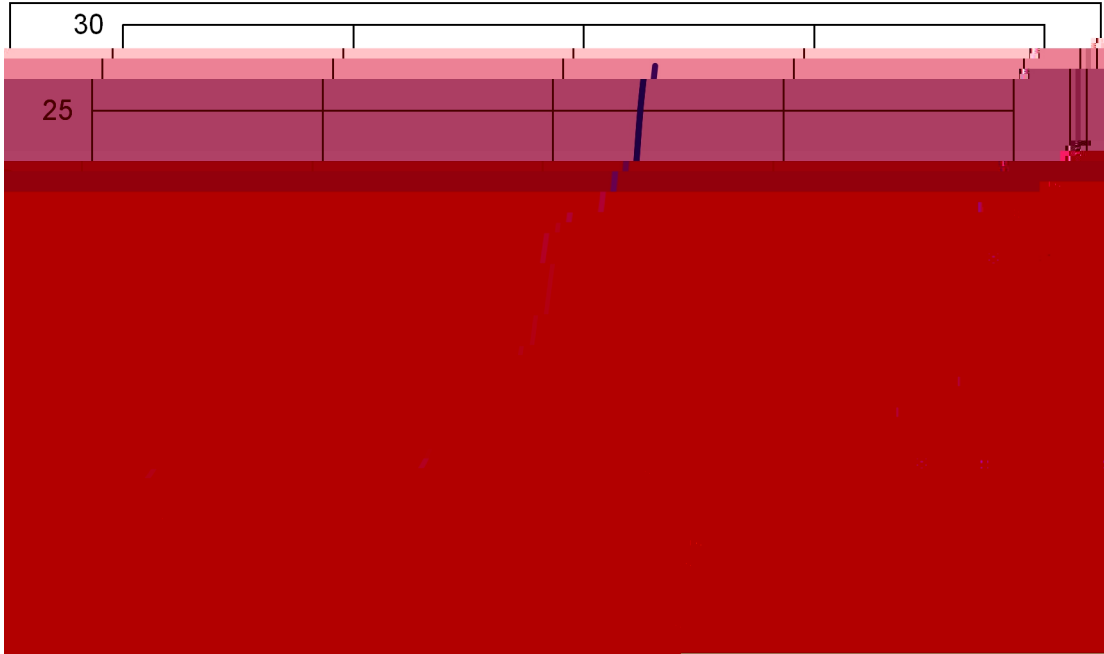

承认专用章

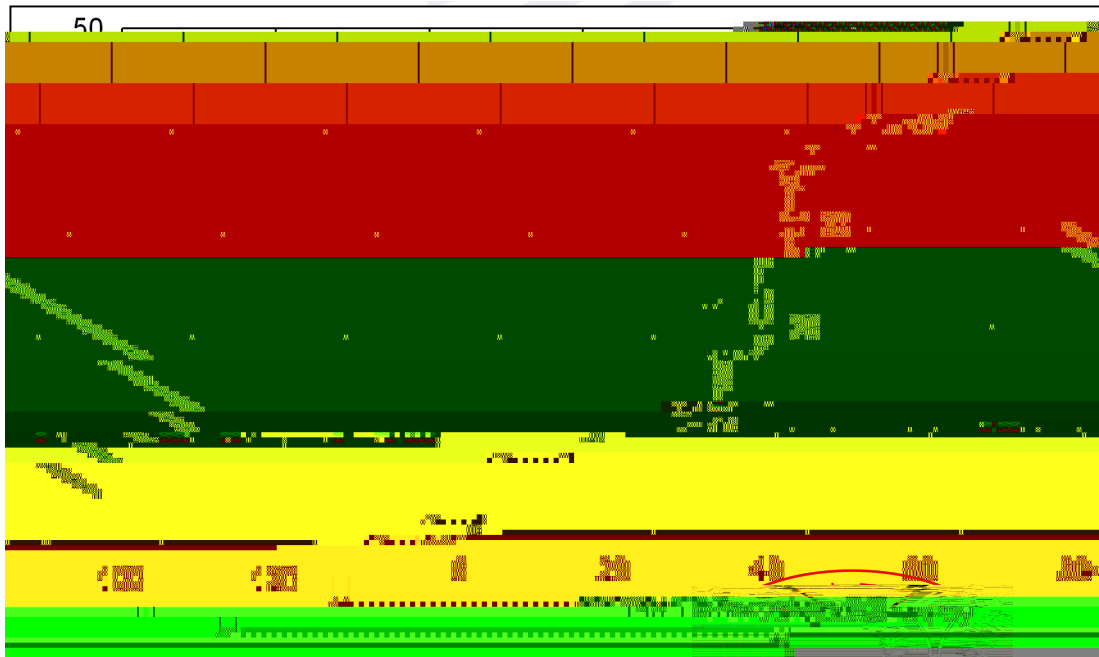
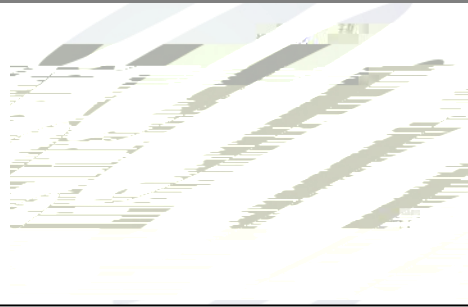
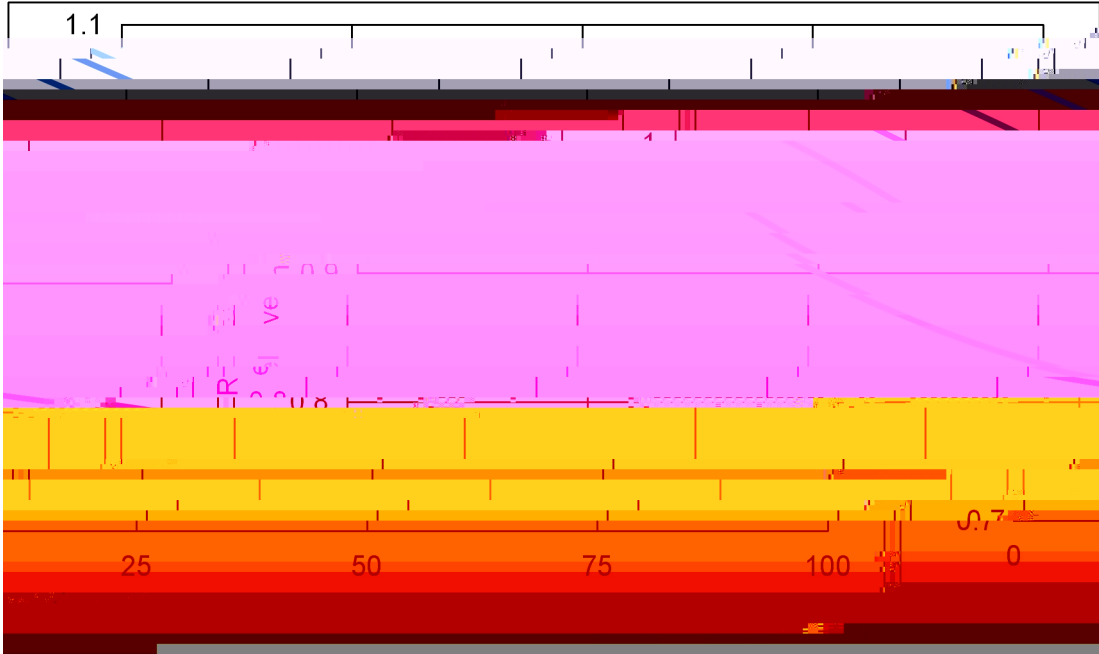

承认专用章

页

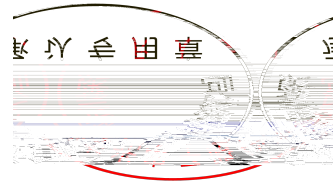

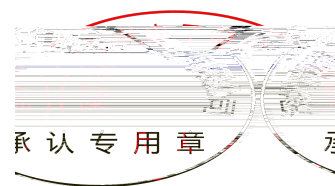
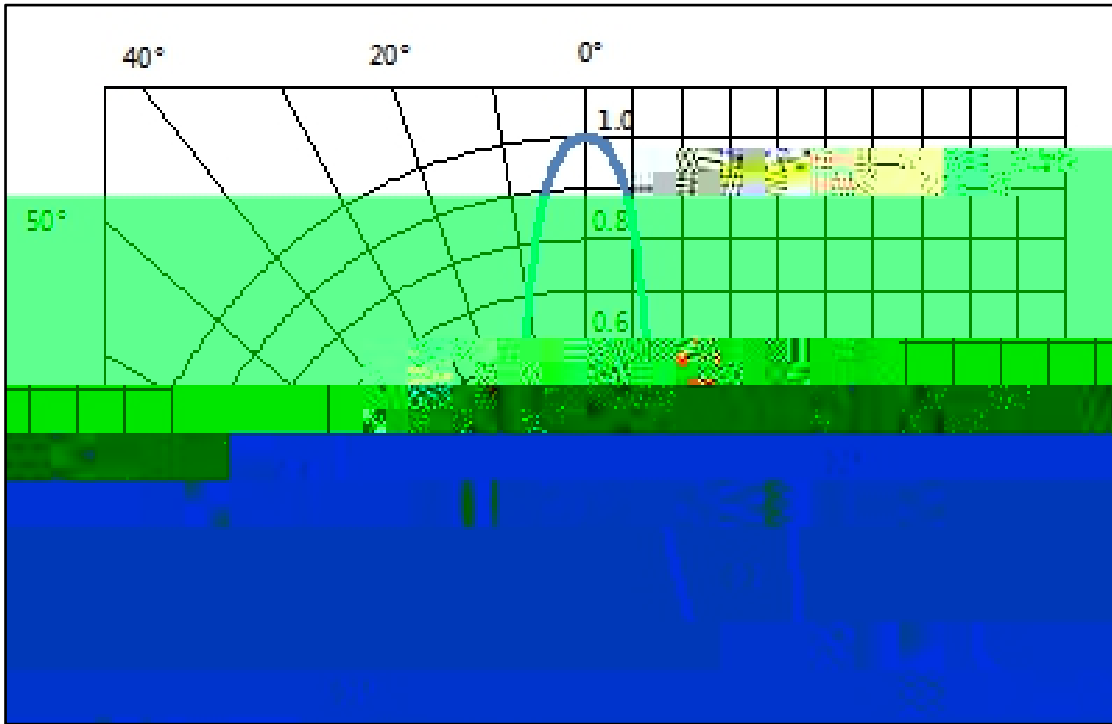

2.

2.1

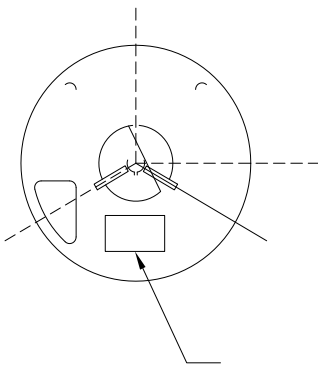
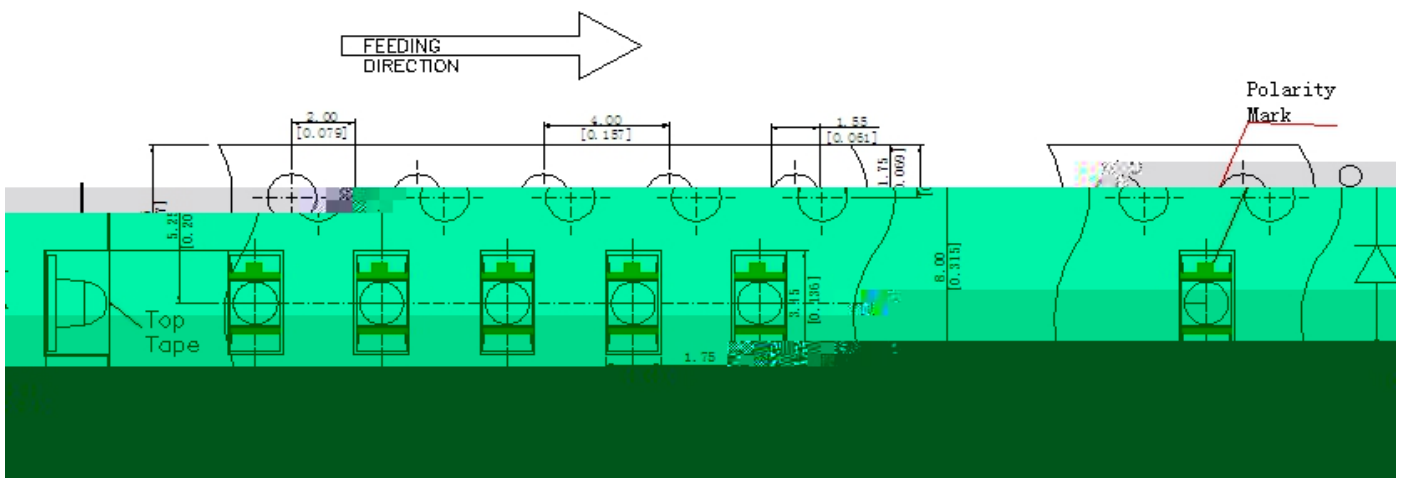

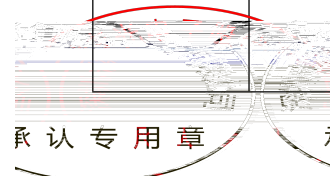

承认专用章

页

PART NO:	
ORDER NO:	
LOT NO:	
BIN CODE:	
IV:	
VF:	
WLD:	
Qty:	
Date:	



2.2

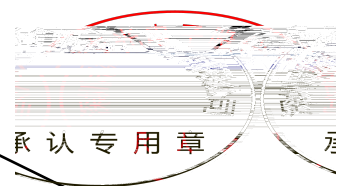
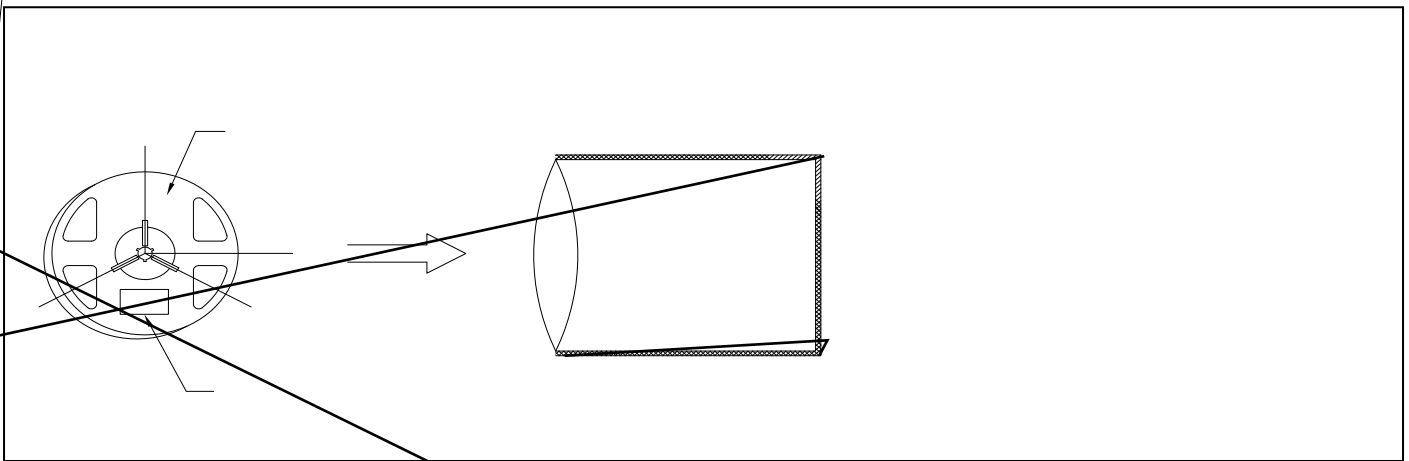

2.3

2.4



2.5

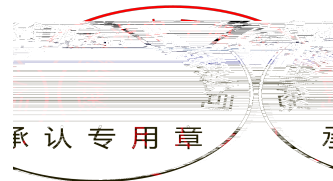

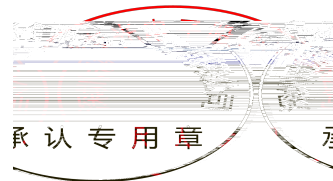

4.

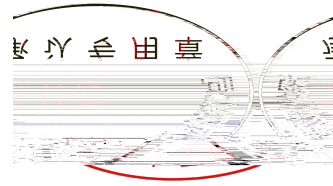

4.1



